**Brown coals and lignites — Determination
of the volatile matter in the analysis
sample —**

**Part 1:
Two-furnace method**

*Charbons bruns et lignites — Détermination des matières volatiles dans
l'échantillon pour analyse —*

Partie 1: Méthode avec utilisation de deux fours

This material is reproduced from ISO documents under International Organization for Standardization (ISO) Copyright License number IHS/ICC/1996. Not for resale. No part of these ISO documents may be reproduced in any form, electronic retrieval system or otherwise, except as allowed in the copyright law of the country of use, or with the prior written consent of ISO (Case postale 56, 1211 Geneva 20, Switzerland, Fax +41 22 734 10 79), IHS or the ISO Licensor's members.



Foreword

ISO (the International Organization for Standardization) is a worldwide federation of national standards bodies (ISO member bodies). The work of preparing International Standards is normally carried out through ISO technical committees. Each member body interested in a subject for which a technical committee has been established has the right to be represented on that committee. International organizations, governmental and non-governmental, in liaison with ISO, also take part in the work. ISO collaborates closely with the International Electrotechnical Commission (IEC) on all matters of electrotechnical standardization.

Draft International Standards adopted by the technical committees are circulated to the member bodies for voting. Publication as an International Standard requires approval by at least 75 % of the member bodies casting a vote.

International Standard ISO 5071-1 was prepared by Technical Committee ISO/TC 27, *Solid mineral fuels*, Subcommittee SC 5, *Methods of analysis*.

ISO 5071 consists of the following part, under the general title *Brown coals and lignites — Determination of volatile matter in the analysis sample*:

— Part 1: *Two-furnace method*

© ISO 1997

All rights reserved. Unless otherwise specified, no part of this publication may be reproduced or utilized in any form or by any means, electronic or mechanical, including photocopying and microfilm, without permission in writing from the publisher.

International Organization for Standardization
Case postale 56 • CH-1211 Genève 20 • Switzerland
Internet central@iso.ch
X.400 c=ch; a=400net; p=iso; o=isocs; s=central

Printed in Switzerland

Introduction

The volatile matter is determined as the loss in mass, corrected for moisture, when an analysis sample of brown coal or lignite is heated out of contact with air under specified conditions. The test is empirical and, in order to obtain reproducible results, it is essential that the rate of heating, the final temperature and the overall duration of the test be carefully controlled. Due to the nature of brown coals and lignites, initial heating of the sample at 400 °C is necessary to minimize the possibility of ejection of sample from the test crucible.

Mineral matter associated with the sample may also lose mass under the conditions of the test, the magnitude of the loss being dependent on both the nature and the quantity of the minerals present.

Brown coals and lignites — Determination of the volatile matter in the analysis sample —

Part 1: Two-furnace method

1 Scope

This part of ISO 5071 specifies a method of determining the volatile matter of brown coals and lignites.

2 Normative references

The following standards contain provisions which, through reference in this text, constitute provisions of this part of ISO 5071. At the time of publication, the editions indicated were valid. All standards are subject to revision, and parties to agreements based on this part of ISO 5071 are encouraged to investigate the possibility of applying the most recent editions of the standards indicated below. Members of IEC and ISO maintain registers of currently valid International Standards.

ISO 1170:1977, *Coal and coke — Calculation of analyses to different bases — Vocabulary.*

ISO 1213-2:1992, *Solid mineral fuels — Part 2: Terms relating to coal sampling and analysis.*

ISO 5068:1983, *Brown coals and lignites — Determination of moisture content — Indirect gravimetric method.*

ISO 5069-2:1983, *Brown coals and lignites — Principles of sampling — Part 2: Sample preparation for determination of moisture content and for general analysis.*

3 Definitions

For the purposes of this part of ISO 5071, the definitions given in ISO 1213-2 apply.

4 Principle

The coal is heated out of contact with air for 7 min at 400 °C, then immediately transferred to another furnace and heated at 900 °C for a further 7 min. The percentage of volatile matter is calculated from the loss in mass of the oven-dried sample or from the loss in mass of the analysis sample corrected for moisture.

5 Reagents

5.1 Desiccants, fresh or freshly regenerated and preferably self-indicating. Suitable desiccants are magnesium perchlorate, silica gel, activated alumina and anhydrous calcium sulfate.

WARNING — Magnesium perchlorate is a strong oxidizing agent. Do not attempt to regenerate the absorbent. Do not permit contact with organic materials or reducing agent.

5.2 Nitrogen, dry, with a maximum oxygen content of 30 μm per litre.

6 Apparatus

6.1 Furnace, (figure 1) heated by electricity. Two such furnaces are required. One furnace shall have a zone of 160 mm \times 100 mm maintained at a uniform temperature of 400 $^{\circ}\text{C} \pm 10$ $^{\circ}\text{C}$. The second shall have a zone of 160 mm \times 100 mm maintained at a uniform temperature of 900 $^{\circ}\text{C} \pm 5$ $^{\circ}\text{C}$. The furnaces may be the stop-ended type or fitted at the back with a flue approximately 25 mm in diameter by 150 mm long.

The heat capacity of the 900 $^{\circ}\text{C}$ and/or 400 $^{\circ}\text{C}$ furnace shall be such that, with an initial temperature of 900 $^{\circ}\text{C}$ and/or 400 $^{\circ}\text{C}$, a temperature of 900 $^{\circ}\text{C} \pm 10$ $^{\circ}\text{C}$ and/or 400 $^{\circ}\text{C} \pm 10$ $^{\circ}\text{C}$ is regained within 4 min after insertion of a cold stand and its crucibles. The temperature shall be measured with a thermocouple as described in 6.3. The furnace can be designed specifically either for multiple determinations using a number of crucibles in one stand or for receiving one crucible and its stand. A position for the crucible stand shall be chosen within the zone of uniform temperature and this position used for all determinations.

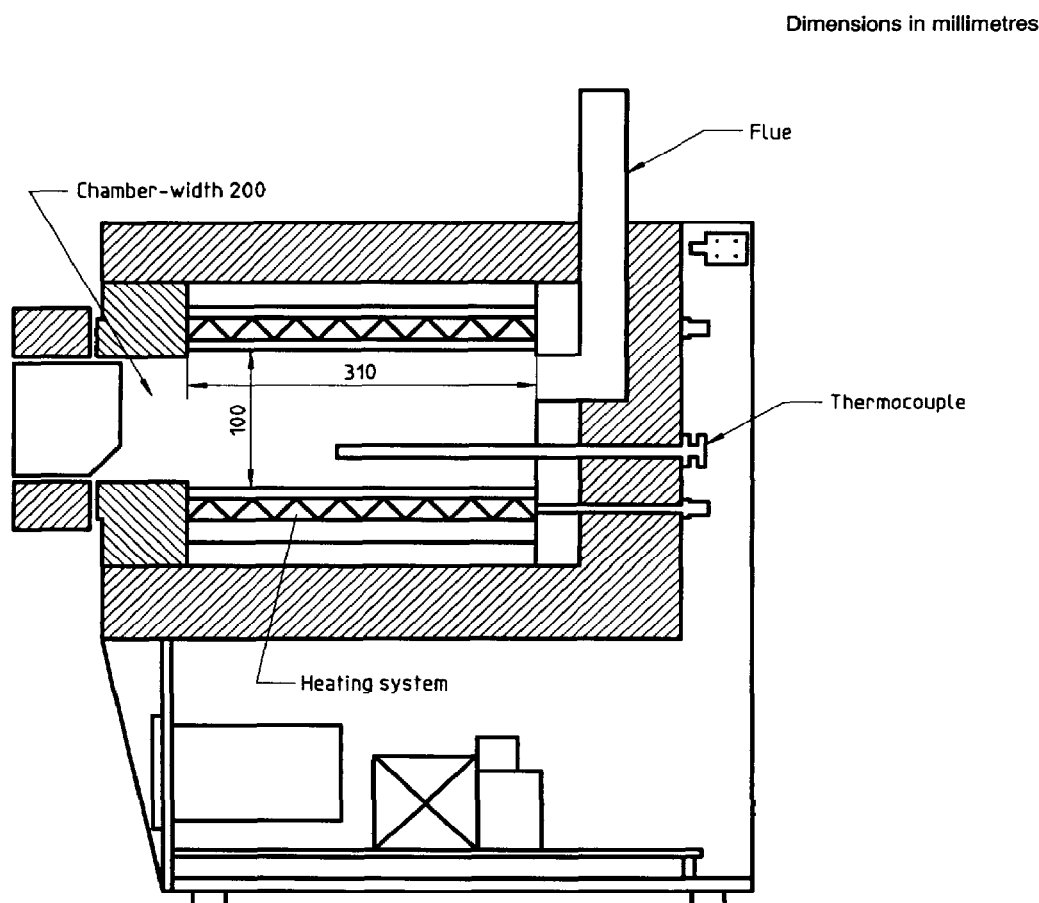

Figure 1 — Example of a suitable furnace

6.2 Oven, capable of being controlled at a temperature within the range 105 °C to 110 °C and with provision for passing a current of dry oxygen-free nitrogen through it at a rate sufficient to change the atmosphere 15 times per hour. The size of the chamber is suitable for containing the crucible (6.4).

6.3 Thermocouple, the temperature characteristics of the furnace shall be checked with an unsheathed thermocouple, of wire not thicker than 1 mm. The thermo-junction shall be inserted midway between the base of the crucible in its stand and the floor of the furnace. If the stand holds more than one crucible, the temperature under each crucible shall be checked in the same manner. If desired, a sheathed thermocouple may be permanently installed in the furnace with its thermo-junction as close as possible to the centre of the zone of uniform temperature; in this case, its temperature readings shall be correlated at frequent intervals with those of the unsheathed thermocouple, which is then inserted only when necessary.

NOTE — The temperature/electromotive force relationship of a thermo-junction maintained at elevated temperatures gradually changes with time.

6.4 Crucible and lid, a cylindrical crucible with a well fitting lid, both made of fused silica. The crucible and lid shall weigh between 10 g and 14 g and have dimensions approximating to those shown in figure 2. The fit of the lid on the crucible is critical to the determination and a lid shall be selected to match the crucible so that the horizontal clearance between them is not greater than 0,5 mm. After selection, the crucible and the lid shall be ground together to give smooth surfaces and then be given a common distinguishing mark. Crucibles of other refractory materials, or of platinum, can be used, provided that they give the results which agree with the recommended silica crucible, within the stated precision of the method (clause 10).

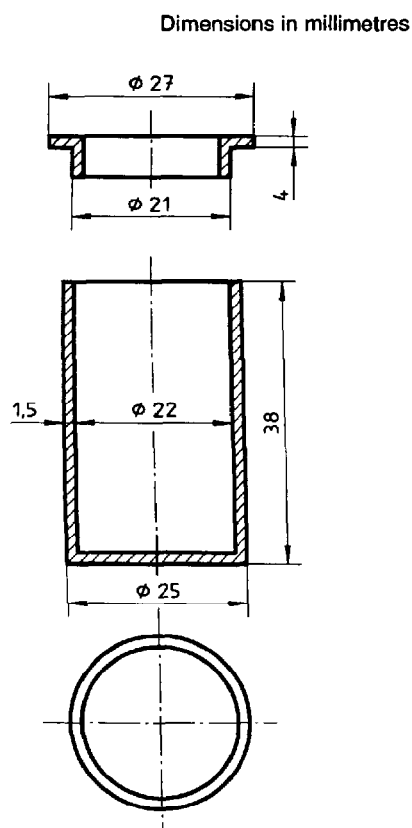

Figure 2 — Silica crucible and lid

6.5 Stand, on which the crucible is placed in the muffle furnace, so that the appropriate specified rate of heating can be achieved. For example, it may consist of the following:

- a) For a single determination — a ring of heat-resistant steel wire as shown in figure 3a), 27 mm in diameter and 1,5 mm thick, resting on the inner projection of its legs.

or

- b) For multiple determinations — a tray of heat-resistant steel wire as shown in figure 3b), of appropriate size, with ceramic plates 2 mm thick supporting the crucibles.

Dimensions in millimetres

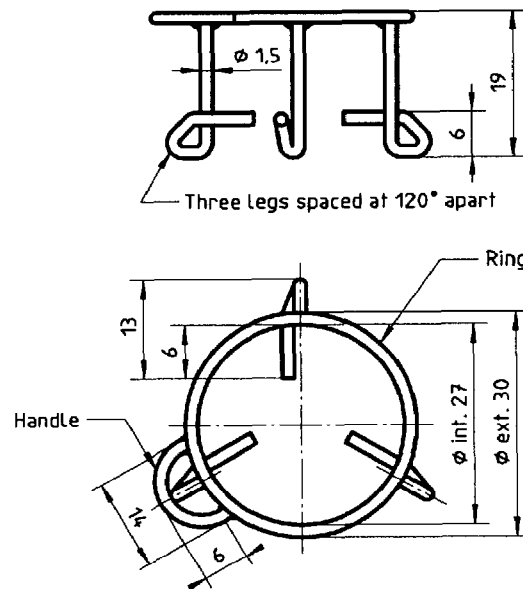

a) Suitable for a single determination

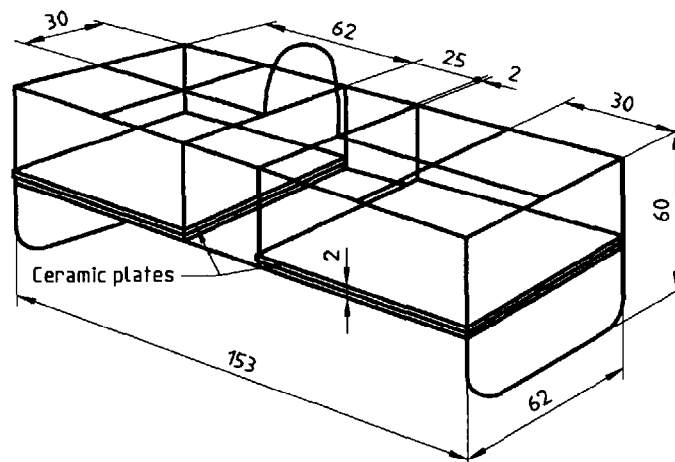

b) Suitable for multiple determinations

Figure 3 — Crucible stands

6.6 Balance, sensitive to 0,1 mg.

6.7 Desiccator.

7 Sample

Prepare the sample for the determination of volatile matter in the analysis sample in accordance with clause 7 (Sample preparation for general analysis) of ISO 5069-2:1983.

8 Procedure

8.1 Preliminary procedure

Adjust the temperature of the zone in the furnaces (6.1), loaded with a stand and empty crucibles where appropriate, to $400\text{ °C} \pm 10\text{ °C}$ and $900\text{ °C} \pm 5\text{ °C}$ respectively as indicated by the correctly unsheathed thermocouple (6.3). Remove the stand and crucibles and close the doors of the furnace. Heat, in a furnace (6.1) at 900 °C for 7 min, either one crucible and lid (6.4) or the requisite number of crucibles and lids to fill the multiple stand. Remove the crucible(s) from the furnace and cool them, first on a metal slab and finally in a desiccator (6.7) located next to the balance. As soon as they are cool, weigh each empty crucible and lid. Record the mass(es) of the preconditioned crucibles and lids to the nearest 0,1 mg (note 1 in 8.4).

8.2 Pre-determination procedure

Before commencing the determination, mix the analysis sample for at least 1 min, preferably by mechanical means. Accurately weigh 1,00 g to 1,01 g of sample (clause 7) to the nearest 0,1 mg into each preconditioned crucible. Replace the lid and tap the crucible on a clean hard surface until the sample forms a layer of even thickness on the bottom of the crucible. Proceed in accordance with either 8.3 or 8.4 depending on whether or not the coal has been oven dried or air dried.

8.3 Method using oven-dried coal

Place the charged crucible(s) with lid(s) removed in the oven (6.2) at 105 °C to 110 °C . Dry the sample(s) to constant mass in accordance with the procedure for moisture determination specified in ISO 5068. Record the mass(es) of the oven-dried crucible(s), lid(s) and sample(s) to the nearest 0,1 mg.

Place the crucible(s) fitted with lid(s) containing the oven-dried sample(s) in a suitable stand (note 2 in 8.4) and transfer to the furnace set at 400 °C for 7 min. Immediately transfer to the furnace set at 900 °C for a further 7 min. Remove the crucible(s) and cool and weigh them in the same manner as for empty crucible(s) (see 8.1). If ash deposits are visible on the stand or crucible(s) then discard the test and repeat (note 3 in 8.4).

8.4 Method using air-dried coal

Place the charged crucible(s) with the lid(s) in a suitable cool stand (note 2) and transfer to the muffle furnace set at 400 °C for 7 min. Immediately transfer to the furnace set at 900 °C for a further 7 min. Remove the crucible(s) and cool and weigh them in the same manner as for the empty crucible(s) (see 8.1).

NOTES

- 1 Precisely similar treatment of the crucible(s) and lid(s) before and after the determination minimizes the effect of any film of water absorbed on its surface, while the rapid cooling reduces absorption of moisture by the coal residue.
- 2 If multiple determinations are being made, fill any vacant places in the stand with empty crucibles.
- 3 Certain brown coals and lignites may consistently produce ash deposits either on the crucible lid or the sample tray when tested using the two-furnace procedure. In such a case, it is recommended to press the air-dried sample into small pellets, then determine the volatile matter.

9 Calculation of results

Calculate the percentage by mass of volatile matter on a dry basis, V_d , according to the formulas in 9.1 and 9.2.

9.1 For oven-dried coal

$$V_d = 100 \times \frac{(m_2 - m_3)}{m_2 - m_1}$$

where

- m_1 is the mass, in grams, of the empty crucible and lid (8.1);
- m_2 is the mass, in grams, of crucible, lid and oven-dried sample (8.3);
- m_3 is the mass, in grams, of crucible, lid and sample after heating in the furnace (8.3).

9.2 For air-dried coal

$$V_{ad} = \frac{100(m_2 - m_3)}{m_2 - m_1} M_{ad}$$

$$V_d = \frac{100}{100 - M_{ad}} \times V_{ad}$$

where

- m_1 is the mass, in grams, of the empty crucible and lid (8.1);
- m_2 is the mass, in grams, of crucible, lid and air-dried sample (8.2);
- m_3 is the mass, in grams, of crucible, lid and sample after heating (8.4);
- M_{ad} is the moisture content, expressed as a percentage by mass, in the air-dried sample, determined according to ISO 5068;
- V_{ad} is the volatile matter on an air-dried basis, expressed as a percentage by mass.

The results (the mean of duplicate determinations) shall be reported to the nearest 0,1 %.

Calculate the results to other bases in accordance with ISO 1170.

10 Precision of the method

10.1 Repeatability limit

The results of duplicate determinations, carried out in the same laboratory by the same operator using the same apparatus on the same sample within short intervals of time, shall not differ by more than the value given in table 1.

10.2 Reproducibility limit

The means of the results of duplicate determinations, carried out in each of two laboratories on representative test portions taken from the same sample, shall not differ by more than the value given in table 1.

Table 1— Precision of the method

Repeatability	Reproducibility
1,0 % absolute	3,0 % absolute

11 Test report

The test report shall include the following information:

- a) a reference to this part of ISO 5071;
- b) an identification of the sample tested;
- c) the result obtained and the method of expression used;
- d) any unusual features noted during the determination.

ICS 73.040

Descriptors: solid fuels, fossil fuels, coal, lignite, tests, high temperature tests, determination of content, volatile matter.

Price based on 7 pages
